

---

# Uniprep 4 Rotary Scraping Tool

---

## Operating Instructions

---

**Product Code: 01-05-002**

Revision: 02



# Helping you make the right connections.

© **Copyright Caldervale Technology Ltd.**

The copyright for this product and instruction manual is held by Caldervale Technology Ltd. Any technical specifications, or illustrations part of this manual cannot be reproduced, used illicitly or distributed in any form for competitive purposes.

<b>Contents</b>	Page
01. Introduction	02
02. Safety Instructions	03
03. Operation	04
04. Removal After Completion	06
05. Specifications	07
06. Parts Diagram	08
07. Warranty Information	10
08. Certificate of Conformity	12
09. Service and Repair	13
10. Decommissioning and Disposal	13

# 01. Introduction

---

## General Description

The pipe preparation tool is designed to provide a fusible surface on any polyethylene pipe material (new, weathered or previously installed). In accordance with Gas Industry Standards GIS/PL2-5 Part 5 Electrofusion ancillary tools.

This product (Uniprep 4) have been manufactured, inspected and tested in accordance with the ISO9001 quality control systems and procedures in place at Caldervale Technology Ltd, Dewsbury.



## Important!

This tool should be used in accordance with the pipe manufacturers' recommendations and in line with local codes of practice.

This manual outlines the operation of the pipe surface preparation tooling for the scraping of polyethylene (PE) pipe and forms a part of the product to which it relates. It should be kept for the life of the product. Any amendments issued by Caldervale Technology Ltd should be incorporated in the text. The manual should be passed to any subsequent holder or user of this product.

## Before Using

It is important to ensure all component parts are present and in serviceable condition. In addition, the condition of the cutting / peeling tip should be checked for damage or excessive wearing.

## 02. Safety Instructions

---

1. Read and understand the whole instruction booklet before using the tool.
2. It is imperative that all possible precautions are made to avoid unexpected pipe movement when the tool is being used.
3. Never use the tool on pipes that are not within the specified dimensions.
4. The tool tip holder spring tension is factory set and **MUST NOT** be tampered with, without adequate training or instruction.
5. Operatives should wear eye protection, gloves, safety headwear and footwear when using the equipment.
6. A single scrape / pass cannot be guaranteed to provide 100% preparation, where this is required users are advised to consider making 2 scrapes around the pipe.

## 03. Operation

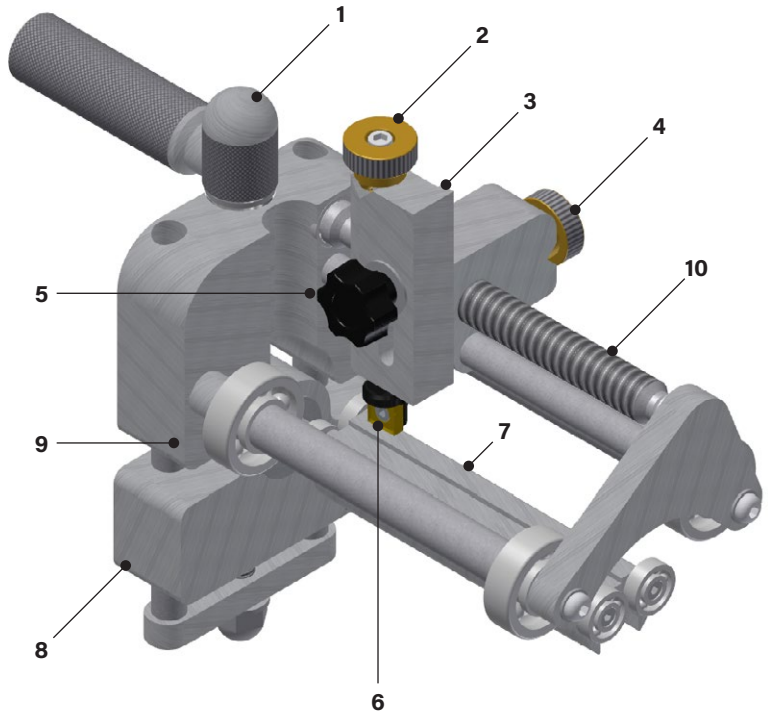

### Instructions for use

1. Ensure that the pipe end is cut square (No more than 2° out of square), is free of burrs and the section to be prepared does not have any deep scores.
2. Mark the pipe outer wall at a point 50% of the length of the coupler plus 10mm.
3. Release the tool post cartridge (3) by loosening the tool post adjustment nut (5), position the tool post cartridge to its highest position and temporarily retighten (5).

4. Lower the underarm slide block (8) by turning the undercarriage adjustment & clamping thumbscrew (1).
5. Position the tool onto the pipe with the tool resting on the axle wheels and with the undercarriage (7) inside the bore of the pipe. The end of the pipe should touch the pipe stop (9).
6. Fix the tool in its operating position by adjusting the under arm adjustment clamping screw (1) until the undercarriage wheels are firmly against the inner wall of the pipe.
7. Slowly rotate the tool around the pipe 2 or 3 times to ensure that it is positioned correctly adjusting the underarm clamping screw (1) to ensure a secure but at the same time ease of rotation.
8. Pull and twist a quarter turn the quick release thumb nut (4) to allow the tool post carriage to move freely along the feed screw (10).
9. Remove the protection cap from the cutter (6) and position the cutter (6) above the mark previously made on the pipe indicating length of peel required, a further quarter turn of the thumb nut (4) will engage the feed screw-drive nut with the feed screw (10).
10. Pull & twist a quarter turn the cutter lifting thumb nut (2) to lift the cutter tip this also applies pressure via the tool tip spring.
11. Release the tool post adjustment nut (5) and **slide the tool post down until the cutter is approximately 1mm from the pipe wall**, now retighten the tool post adjustment nut (5) to fix the tool post in its correct operating position.
12. A further quarter turn of the cutter lifting thumb nut (2) will lower the cutter on to the pipe wall surface and the correct pressure will be applied to the tip (6) via the tool tip spring.
13. Rotate the tool around the pipe in a steady clockwise direction, the cutter will travel towards the pipe end removing a continuous strip of PE the process may be halted from time to time to remove surplus peel.

## 04. Removal After Completion

---

1. On completion, the scraped section should be inspected for areas of un-scraped pipe. If necessary the pipe can be scraped again.
2. To remove the scraper, loosen the tool post locking screw (5) and raise the tool post clear of the pipe and retighten (5). Loosen the underarm pressure screw (6) to release the undercarriage wheels and remove the scraper from the pipe. Refit the protective cover to the cutter tip when not in use.



### Storage

#### **IMPORTANT! When not in use always:**

1. Store the tool in the tool box.
2. Ensure the tool tip tension is released.
3. Ensure the tool is clean and dry before storage.

### Routine Maintenance

1. Check for correct movement and operation and lubricate moving parts at regular intervals before using.
2. It is important to ensure all component parts are present and in serviceable condition. In addition, the condition of the cutting / peeling tip should be checked for damage or excessive wearing.
3. The cutter tip can be replaced. Spares are indicated in the parts diagram.



## 05. Specifications

---

<b>Materials:</b>	Mild Steel EN3A, Stainless Steel, Aluminum, Brass and Tungsten Carbide
<b>Finish:</b>	Natural / Zinc passivate to mild steel
<b>Dimensions:</b>	L360 x W160 x H290mm
<b>Depth of Cut:</b>	0.3mm
<b>Max Scrape Length:</b>	165mm, feed per rotation 4.5mm
<b>Min - Max Pipe Size:</b>	63 - 250mm All SDR Ratings
<b>Weight:</b>	3.20kg (Excluding tool box) 7.44kg (Including tool box)
<b>Product Code:</b>	01-05-002

This unit is design and manufactured to meet the requirements of National Grid Gas Industry Standards GIS/PL2-5 Part 5 Electrofusion ancillary tooling.

Caldervale Technology Ltd has a policy of continuous improvement in product quality and design. Caldervale Technology Ltd therefore reserves the right to change the specification of its models at any time, without prior notice.

---

**It is the responsibility of the operator to ensure that the PE pipe is suitable for pipe preparation if in doubt contact the PE pipe manufacturer for confirmation.**

## 06. Parts Diagram

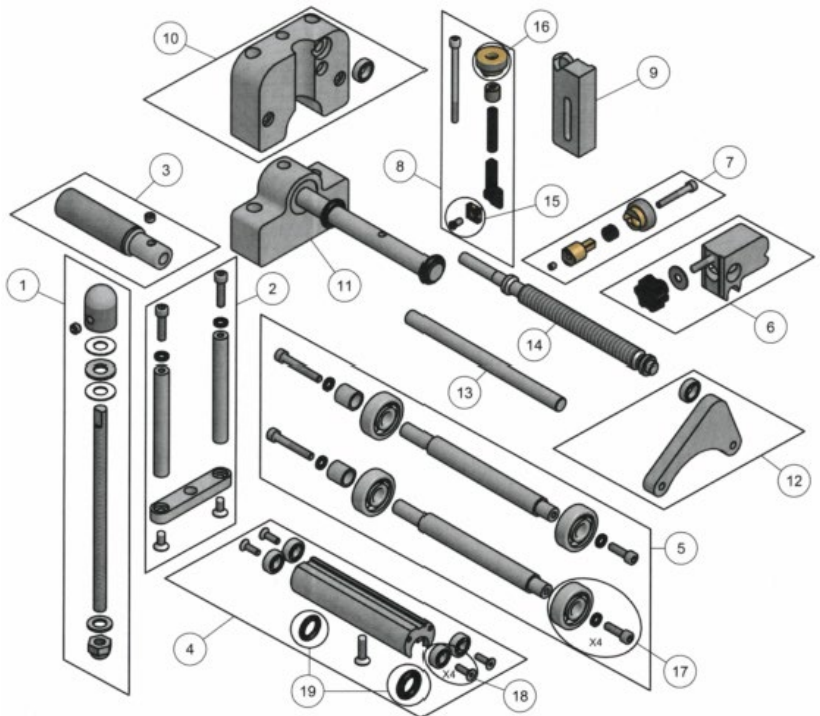

Part	Product Code	Description
1	01-02-051	Under Arm Clamping Screw Repair Kit
2	01-02-052	Under Arm Slide Shaft Repair Kit
3	01-02-053	Handle Repair Kit
4	01-02-054	Undercarriage Repair Kit
5	01-02-055	Axel Repair Kit
6	01-02-056	Tool-post Carriage Repair Kit
7	01-02-057	Quick Release Button Repair Kit
8	01-02-058	Cutting Tip & Holder Repair Kit

<b>Part</b>	<b>Product Code</b>	<b>Description</b>
9	Z01-02-312	Tool-post Carriage
10	01-02-060	Upper Body Repair Kit
11	01-02-061	Under Arm Body Repair Kit
12	01-02-062	Axel End Plate (Boomerang) Repair Kit
13	Z01-02-305	Stabilizer Shaft
14	Z01-02-306	Feed Screw
15	01-02-023	Cutting Tip & Screw
16	Z01-02-011	'V' Button
17	01-02-067	Axel Bearing Repair Kit
18	01-02-068	Undercarriage Bearing Repair kit
19	01-02-069	Under Arm 'O' Ring Repair Kit

## 07. Warranty Information

---

### 1. Extent of Warranty

- a) Subject to clauses 2 and 3, Caldervale Technology Ltd warrants to the end-user customer that its products will be free from defects in materials and workmanship, for six months after the date of purchase by the end-user customer, subject to providing proof of purchase.
- b) If Caldervale Technology Ltd receives, during the warranty period, notice of a defect in product which is covered by this warranty; Caldervale Technology Ltd shall either repair or replace the product, at its option. Any replacement product may be either new or like-new, provided that it has functionality at least equal to that of the product being replaced.
- c) All warranty work will be carried out by Caldervale Technology Ltd unless otherwise agreed. On-site warranty and repair or replacement services are available from authorised Caldervale Technology Ltd service facilities world-wide.
- d) Customers shall prepay shipping charges for products returned to Caldervale Technology Ltd for warranty service, and Caldervale Technology Ltd will charge for return of the products back to the customer.
- e) This warranty statement gives the customer specific legal rights. The customer may also have other rights which vary from country to country in the world.

### 2. Pre-conditions for Warranty Application

Caldervale Technology Ltd's warranty covers only those defects which arise as a result of normal use of the product, and this warranty shall only apply in the following circumstances:

- a) All the instructions contained in the operating manual have been complied with; and
- b) None of the following apply:
  - i) Improper or inadequate maintenance;
  - ii) Physical abuse;
  - iii) Unauthorised modification, misuse or any use not in accordance with the operating manual and good industry practice;

- iv) Operation outside the products specifications;
- v) Improper site preparation or maintenance;
- vi) Faulty pipes.

### 3. Limitations of Warranty

- a) Caldervale Technology Ltd does not warrant the operation of any product to be uninterrupted or error free.
- b) Caldervale Technology Ltd makes no other warranty of any kind, whether express or implied, with respect to its products. Caldervale Technology Ltd specifically disclaims the implied warranties of satisfactory quality and fitness for a particular purpose.
- c) To the extent that this warranty statement is inconsistent with the law of the locality where the customer uses the product, this warranty statement shall be deemed modified by the minimum necessary to be consistent with such local law.
- d) To the extent allowed by local law, the remedies provided in this warranty statement are the customer's sole and exclusive remedies.
- e) This tool has been designed for the range of pipes available at the time of its design and development. Caldervale Technology Ltd can accept NO liability for the unit's ability or otherwise to work with new or different pipes that subsequently appear in the market place.

---

**Please complete this information and keep it safely with your proof of purchase receipt. You will require it for any warranty claim.**

Where purchased: \_\_\_\_\_

Date of purchase: \_\_\_\_\_

Name of purchaser: \_\_\_\_\_

Address of purchaser: \_\_\_\_\_

\_\_\_\_\_  
\_\_\_\_\_

Type of tool: \_\_\_\_\_

Serial number: \_\_\_\_\_

## 08. Certificate of Conformity



### Certificate of Conformity

This document certifies that the product detailed below fully conforms to the following standard without derogation.

**GIS/PL2-5:2018 Electrofusion Ancillary Tools**

**Uniprep 4 Rotary Scraping Tool**

**MARCH 2019**

**I. Smith**  
Managing Director



**Caldervale Technology Ltd**  
Bretfield Court, Dewsbury, West Yorkshire WF12 9BG, UK  
CRN 2769288 | ISO 9001:2015 Certified FM 30989

## 09. Service and Repair

---

This product has no specific calibration period, however periodic safety inspections should be carried out by the operator as specified in this manual, if in any doubt please contact the manufacturer for further information.

For service and repair please contact:

### INTERNATIONAL

#### **Caldervale Technology Ltd**

Bretfield Court, Dewsbury,  
West Yorkshire WF12 9BG, UK

T. +44 (0)1924 469571

E. [sales@caldertech.com](mailto:sales@caldertech.com)

W. [caldertech.com](http://caldertech.com)

### AUSTRALIA / NZ

#### **Caldertech Australia Pty Ltd**

Unit 3/30 Juna Drive,  
Malaga WA 6090, Australia

T. +61 (0)8 9209 1132

E. [sales@caldertech.com.au](mailto:sales@caldertech.com.au)

W. [caldertech.com.au](http://caldertech.com.au)

## 10. Decommissioning and Disposal

---

These give the instructions for decommissioning and disposal of the equipment and confirm how it is to be taken out of service safely, in respect of the Essential Environmental, Health and Safety Requirements.

- If a Caldertech pipe preparation tool has reached the end of its useful working life and cannot be refurbished it must be sent to a licensed recycling facility for treatment. That will ensure the waste hierarchy requirements are met.
- End of life treatment is the responsibility of the Customer. This can also be achieved by returning the product back to the manufacturer if required.

**INTERNATIONAL**

**Caldervale Technology Ltd**

Bretfield Court, Dewsbury,  
West Yorkshire WF12 9BG, UK

T. +44 (0)1924 469571

E. [sales@caldertech.com](mailto:sales@caldertech.com)

W. [caldertech.com](http://caldertech.com)

---

**AUSTRALIA / NZ**

**Caldertech Australia Pty Ltd**

Unit 3/30 Juna Drive,  
Malaga WA 6090, Australia

T. +61 (0)8 9209 1132

E. [sales@caldertech.com.au](mailto:sales@caldertech.com.au)

W. [caldertech.com.au](http://caldertech.com.au)



**Caldertech**  
**.com**