

**RAIN BIRD.**



## Vigilec Mono

INSTALLATION AND STARTING INSTRUCTIONS	ENGLISH
NOTICE D'INSTALLATION ET DE MISE EN SERVICE	FRANÇAIS
INSTRUCCIONES DE INSTALACION Y USO	ESPAÑOL
INSTRUÇÕES DE INSTALAÇÃO E USO	PORTUGUÊS
MANUALI DI INSTRUZIONE	ITALIANO
INSTALLATIONSHINWEISE UND INBETRIEBNAHME	DEUTSCH
HANDLEIDING VOOR INSTALLATIE EN GEBRUIK	NEDERLANDS
ΟΔΗΓΙΕΣ ΕΓΚΑΤΑΣΤΑΣΗΣ ΚΑΙ ΕΚΚΙΝΗΣΗΣ	ΕΛΛΗΝΙΚΑ
MONTAJ VE BAŞLANGIÇ TALİMATLARI	TÜRKÇE

## Installation and connection

We recommend to connect individual connecting tag wires to the terminal blocks (MAX. wire size: 4 mm<sup>2</sup>).

- 1.- Slide open the front cover and put on upper position (fig.A).
- 2.- Connect MAIN SUPPLY (fig. B, knob 1) and the MOTOR (fig. B, knob 2) to the respective terminal blocks.
- 3.- Connect the PROBES (if necessary) to the respective terminal blocks (fig. B, knob 3). Lower probe (red) will be installed some centimetres higher than the pump intake. Upper probe (yellow) will be installed according to well level and volume, at suitable height based on optimal flow.

(fig. B, knob \*) 1 probe mode: connect low level probe and link terminals 1 and 2.

(fig. B, knob \*\*) Without probes mode: link terminals 2 and GROUND.

Probe cables of probes must be sufficiently insulated, since a contact or derivation to earth could cause defective operation of the equipment. The maximum length recommended for the probe cables is about 300 metres and the minimum section, 0,5 mm<sup>2</sup>.

A correct ground connection is necessary for the proper operation of the control level. It is recommended to connect to any point of the pipe or the pump (screw, flange, valve), to a stake, or by means of a third probe submerged in the bottom of the recipient, in case it is insulated (fibreglass and plastics in general). Protected against incorrect connections.







- 4.- REMOTE terminals (fig B, knob 4) can be connected to a remote control device (see Starting). Protected against incorrect connections. If this input is not used, it must also be linked.

**IRRIGATION SYSTEMS:** In applications with irrigation controller or other control devices (REMOTE terminals), it is recommended to use the control box in 1 probe (\*) mode (see Starting).

## Inside configuration (fig. C)

- |                                      |                                          |                                     |
|--------------------------------------|------------------------------------------|-------------------------------------|
| 1.- Control fuse (0,1A).             | 6.- Maximum current adjust.              | 10.- Output motor gland.            |
| 2.- Transformer.                     | 7.- Terminal blocks.                     | 11.- Input probes and ground gland. |
| 3.- Air alarm output contact (N.O.). | 8.- Space for capacitor (borehole pump). | 12.- Input remote gland.            |
| 4.- Flat cable connector.            | 9.- Input main supply gland.             |                                     |
| 5.- Minimum current adjust.          |                                          |                                     |

## Front configuration (fig. D)

- 1  **START** button: **AUTOMATIC** mode (green circle lamp ON): press button and the unit will work automatically with established control and protections. **MANUAL** mode (green circle lamp flashing): pump running in undermanual mode. Overload and underload motor protection on. Release the button to return to the Automatic mode.
- 2  **STOP** button: the unit stops the motor and no starting is possible in any circumstances. If voltage failure occurred, the established operation mode (STOP-AUTO) remains memorized, to continue in the same mode when voltage is restored.
- 3  **Red lamp: MOTOR ALARM.** **Red ON:** EXCESSIVE CURRENT alarm trip in 7 s. **Red flashing:** INSUFFICIENT CURRENT alarm trip in 3 s.
- 4  **ON** Green lamp: **MOTOR RUNNING.**
- 5  **Amber lamp: LOW LEVEL.** **Amber ON:** indicates a low water level detection (2 probes mode). **Amber flashing:** 15 minutes after preset time after low water level detection (1 probe / without probes mode).
- 6  **RESET** **RESET** button: restart the unit after EXCESSIVE CURRENT or INSUFFICIENT CURRENT alarm.
- 7  **Green lamp: VOLTAGE.** Green ON when AC supply is present.

## Starting (fig. E)

**TWO PROBES (fig. E, knob 1).** In this selection mode, it is necessary to previously connect low (\*\*) and high (\*\*) level probes. The pump will start when the water level exceeds the high level probe (amber lamp OFF), and will stop when it descends below low level probe (amber lamp ON).

Select this mode when you want to keep water level between two fixed limits.

**ONE PROBE (fig. E, knob 2).** In this selection mode, it is necessary to previously connect low level probe (\*\*) and link terminals 1 and 2.

The pump will stop when water level descends below low level probe (amber lamp flashing) and will restart automatically 15 minutes after preset time.

Select this mode when you want to obtain optimal well flow.

**WITHOUT PROBES (fig. E, knob 3).** In this selection mode, it is necessary to link terminals 2 and GROUND.

When the pump is dry running, it will activate the underload detection and it will stop the pump (amber lamp flashing).

Then, the pump will restart automatically 15 minutes after preset time.

If after restarting, the pump is running less than 1 minute, then the unit will trigger to activate alarm (red lamp flashing). Press RESET to start.

This is suitable for installations where probes cannot be installed.

In this mode, it is necessary to use a borehole or self-priming pump.

### REMOTE CONTROL (only AUTO mode)

The REMOTE control: terminals 3 and 4 (fig. B, knob 4) can be used to control the pump from an external unit, through an external contact that will activate the pump and it stops. Also, you can control the remote by applying voltage to this input, from 6 up to 400 Vac/Vdc. You can use to connect the following devices: floats, pressure switch, timer, presscontrol, irrigation controller, radio-control, etc.  
If this function is not used, the terminal blocks must be linked. Also, if you want to operate the pump only by this remote control, without automating the level probes, it is necessary to link terminals 2 and GROUND.

### OTHER FUNCTIONS

**Pump jamming prevention:** to prevent pump jamming (long rest periods), the unit activates the motor during 1 second every 24 hours of stop pumping (only AUTO mode)

**Detection of lack of air in pressure tank:** when the unit works with a booster set, an intelligent system of detection of lack of air in pressure tank is activated. When it is detected that the pump starts with a rate higher than 30 starts per hour, the detection is activated, closing the output (terminals 5 and 6; external contact). This alarm output will only be active when the pump is running and will restart automatically when the start rate is lower than 30 per hour, when RESET button is pressed.

The alarm output will only be active during 3 minutes max., although the motor continues running. This allows installation of a compressor that injects air automatically into the pressure tank in case of pressure loss.

### Excessive current and Insufficient current adjustment

See adjustment cursors inside the box (fig. C, knobs 5 and 6). A small screwdriver is needed for these adjustments.

#### VERY IMPORTANT:

The adjustment is possible only if the motor is connected to the unit, otherwise, the INSUFFICIENT CURRENT alarm will be activated.

For complete protection of the pump a correct EXCESSIVE CURRENT and INSUFFICIENT CURRENT adjustment is necessary as shown:

**EXCESSIVE CURRENT (fig. C, knob 6):** Start the motor and notice run-up time. Then turn slowly the potentiometer CCW, until the red pilot flashes (the actual load current is indicated). Then adjust +5% or +10% depending the desired sensitivity of excessive current tripping.

**INSUFFICIENT CURRENT (fig. C, knob 5):** The normal adjustment, set this knob to half (50%) of the preset "I.max." set point.

### Technical features

Main supply	230 Vac - 50/60 Hz
Permissible voltage fluctuations	±20% - Auto trigger after that +30%
Maximum current	18 Amp AC3
Excessive current adjustment	0-18 A (adjustable)
Insufficient current adjustment	0-18 A (adjustable)
Probe operating voltage	24 Vac
Probe sensitivity	9 Kohm
Remote control connection	Contact or voltage (6 to 400 Vac/Vdc)
Lack of Air output contact (option)	AC1 : 2 A - 250 Vac AC11 : 1 A - 230 Vac
Terminal blocks	4 mm <sup>2</sup>
Mounting	Wall mounting
Weight	850 g
Protection	IP56
Operating temperature range	-10 +55 °C

#### EC DECLARATION OF COMPLIANCE WITH THE "LOW VOLTAGE" & "ELECTROMAGNETIC COMPATIBILITY" DIRECTIVES.

LINEA ELECTRONICA, S.L. declares that the equipment described in this manual complies with the provisions of the modified "LOW VOLTAGE" directive (Directive 73/23/EEC) and with the modified "ELECTROMAGNETIC COMPATIBILITY" directive (Directive 89/336/EEC) and with national legislation based upon them. It also complies with the provisions of the following European standards and draft standards:  
NF EN 60.439-1 / EN 50.081-1 / EN 50.082-2.



### Troubleshooting

Problem	Cause	Solution
The equipment does not work and the voltage light is off even when the system is connected to a power source.	- Control fuse is burned out.	- Check and replace voltage fuse (5x20 / 0,1A).
The motor alarm lights up (indicator light "3").	- Inside excessive current adjustment very low or critical. - Motor overload. - Motor underload.	- Check the excessive current adjustment. - Check the pump (surge, etc). - Check the pump (dry well, dead head, etc).
Level control does not correctly operate.	- High and low level probes inverted. - Ground connection incorrect. - Probes or Remote wire cut.	- Place the probes in correct position. - Check the ground connection. - Check the wire.

Fig. A

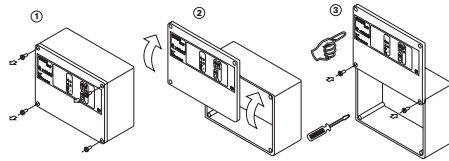

Fig. B

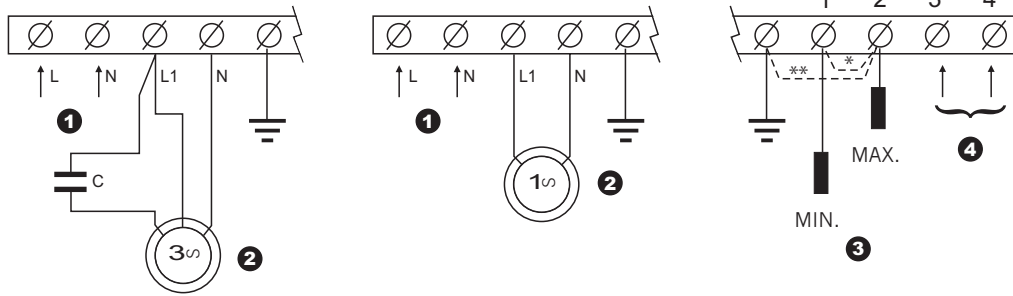

Fig. C

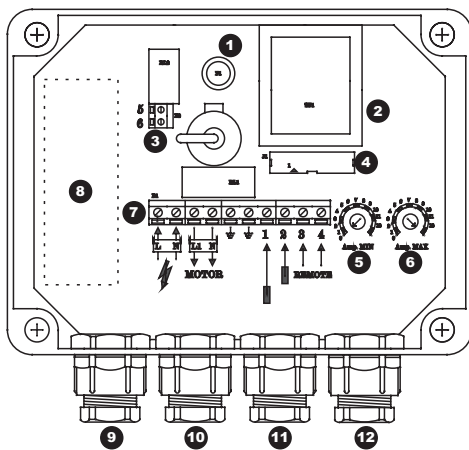

Fig. D

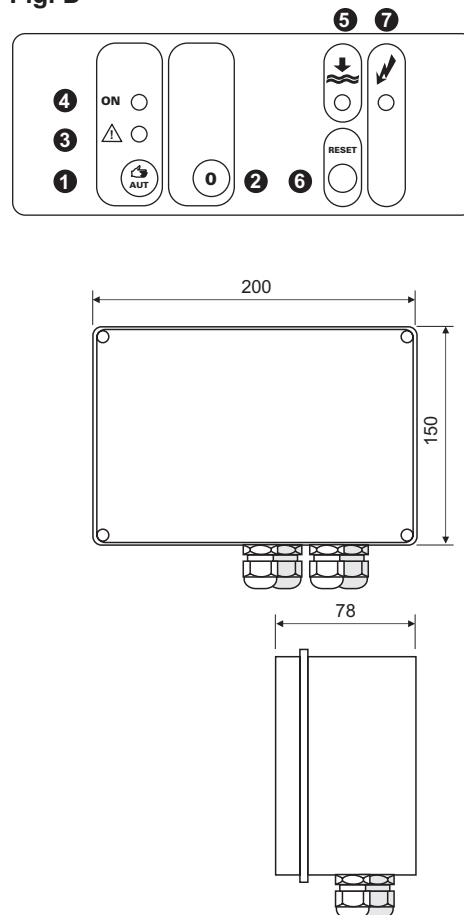
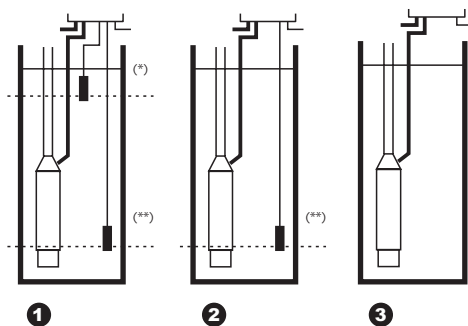

Fig. E





RAIN BIRD EUROPE, S.A.R.L.  
900, rue Ampère  
Z.I. Les Milles  
13792 AIX EN PROVENCE  
FRANCE  
Tél.: +33 (0) 4 42 24 44 61  
Fax: +33 (0) 4 42 24 24 72

ITM-0001-ED8

**RAIN  BIRD®**